

VOLKAN200



**RANGE OF COLOUR
OPTIONS AVAILABLE**

Please note colours may vary

designed and
manufactured in the UK



For more information contact:

+44 (0) 1905 362100

www.wastespectrum.com

MEDIUM CAPACITY INCINERATOR

Volkan is a range of highly efficient incineration units for the disposal of all types of animal carcass. They are extremely robust, constructed using high quality materials and are available in a range of capacities to suit every disposal problem.

The Volkan200 is a powerful incinerator featuring an integral after-burner, making it compliant with European legislation. It is ideal for the disposal of poultry, sheep, medium sized animal carcasses, farm shop waste and abattoir waste.

It is a DEFRA 'Type Approved', compact, easy to use, top-loading incinerator which easily accommodates medium sized volumes of waste. The operator selects a burn program and can leave the incinerator unattended until the waste has been reduced to ash.

With a burn rate of up to 50kg per hour, the Volkan200 has a low-capacity status requiring no planning permission for farm use. It is highly efficient, utilising automatic high heat-rate burners, low thermal mass linings and timer controls that ensure minimal running costs; a thermostat triggers burner shut-off when optimum temperatures are reached, increasing fuel efficiency significantly. The model is designed to use the inherent fuel properties within animal fat that aid combustion.

Easily installed on site, it simply requires concrete hardstanding and a 230 volt electricity and fuel supply.

A comprehensive operating, care and maintenance manual is provided with each incinerator.



designed and
manufactured in the UK



WHY BUY WASTE SPECTRUM?

Ultimate bio-security • Efficient, low cost disposal • Controlled environmental emissions
Low maintenance costs • Simple on-site installation

Volkan200	
OVERALL LENGTH	2270mm
OVERALL WIDTH	1530mm
OVERALL HEIGHT	4130mm
WEIGHT	2680kg
CHAMBER VOLUME	0.55m ³
LOAD CAPACITY	Up to 200kg
LOAD METHOD	Top
BURN RATE	50kg/hr
FUEL OPTIONS	Diesel, LPG, Natural Gas or Bio Gas
TYPICAL FUEL CONSUMPTION*	Diesel: 6-8 litres/hr LPG: 6-8 litres/hr Natural Gas: 7-9 Nm ³ /hr
SECONDARY CHAMBER	✓
ELECTRICAL SUPPLY NEEDED	230V
CONTROL PANEL	✓
CONTROL	Internal PLC system
HEARTH BARS	X
ASH REMOVAL	✓
DE-ASH METHOD	Top (Optional front de-ash door)
ABPR 1069/2009 COMPLIANT	✓
MOBILE AVAILABLE	✓
WARRANTY	12 month standard

*Figures based on typical figures gained from an average burn cycle.

Waste Spectrum Environmental Ltd continually strives to improve its products and therefore reserves the right to introduce modifications to their product range without notice.

The Volkan200 is compact, fuel efficient and easy to run, designed to achieve its optimum incineration temperature quickly. It is the ideal solution for medium volume incineration. Constructed from high quality materials in the UK, it comes with one year's free warranty.

It is fitted with an after-burner which is integral to the incinerator. The gas temperature reaches 850°C rapidly and is maintained until the end of the main burn cycle. Highly efficient automatic burners and timer controls ensures cleaner emissions and compliance with European emissions legislation ABPR 1069/2009.

Specifically designed for the incineration of:

- poultry • sheep • medium pets • farm shop waste
- abattoir waste

Control

Internal PLC System providing control of:

- secondary chamber pre-heat • burn cycle (variable)
- cool down cycle

Burners

Fully automatic, high-efficiency burners with electronic ignition, flame recognition and combustion control devices fitted ensuring maximum fuel efficiency.

De-ash method

Manual ash removal from the primary chamber (optional front de-ash doors are available on request).

Construction

Mild steel welded fabrication consisting of sheet steel.

Lining

Monolithic high grade refractory concrete with high grade insulation backing. No bricks to fail. Thermally efficient.

Exterior finish

High quality, high temperature, silicon enamel paint. Range of colour options available.

Warranty

Extended/lifetime warranties and service agreements available upon request.



For more information contact:

+44 (0) 1905 362100

www.wastespectrum.com

GO PRO

Our Professional range has all the advantages offered by the standard range, but in addition is built to withstand the extremely high temperatures and toxins that result from the incineration of waste streams such as medical and municipal waste. High grade refractory concrete is used in all our Professional models.

The Professional range also has additional dilution air to aid the combustion of this much tougher waste stream and gives the operator the ability to fine tune the incinerator to suit the specific waste being burnt. Again, this range is ideal for when the machine is required to run non-stop for long periods.

TECHNICAL DRAWING

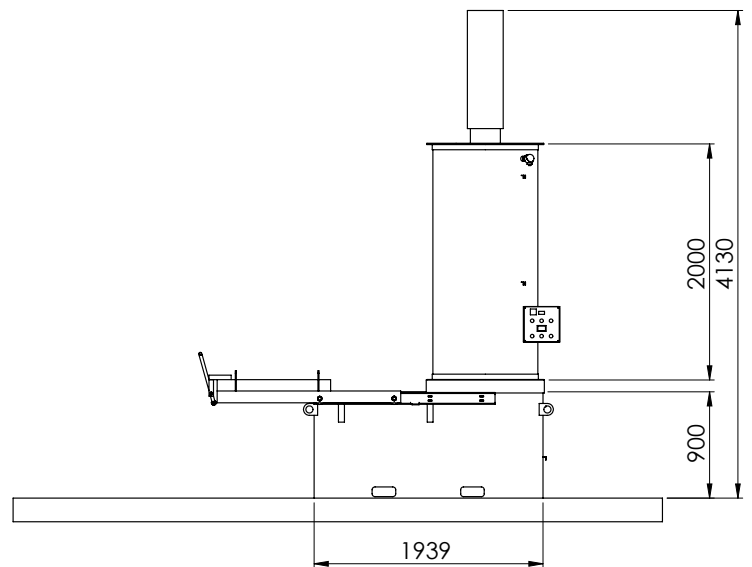
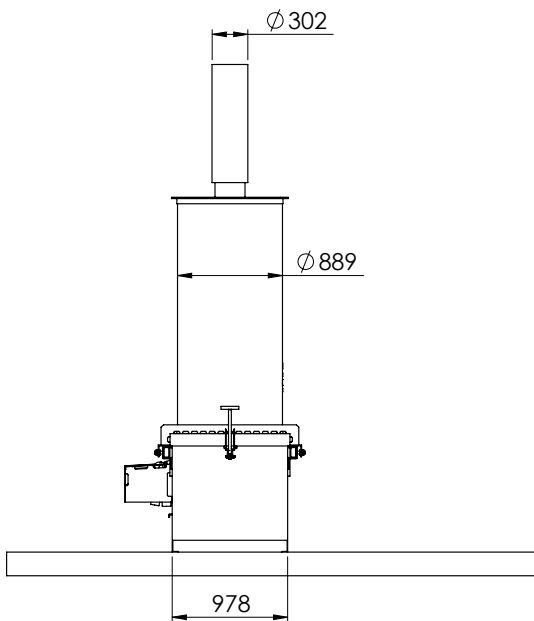
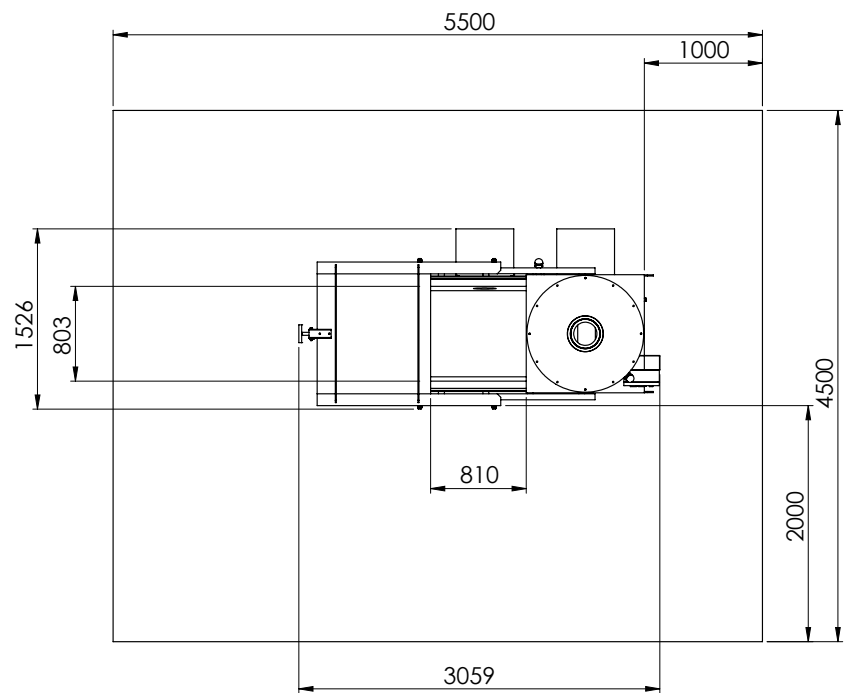

designed and
manufactured in the UK



For more information contact:

+44 (0) 1905 362100

www.wastespectrum.com